



Quick Check Commercial™
Installation

NOTE: See form QM07936-05 for complete information, including environmental specifications and UL certifications.

Site Specifications	
Power Requirements	115/230v, 15 amp* 50/60 Hz 1 ph ¹
Internet Connection	Hardwired, 20+mbps up and down, Ping Spread faster than 1000 ms.
Operating System	Windows® 10 - 64 Bit
Cable Length	22 m / 75 ft. per tower (Cat5e)
Product Specifications	
Min Req. Light Condition	600 Lux
Test Entry Speed	2 to 8 mph (3-13 km/h)
Shipping Weight	
Quick Check Cabinet (Intern.)	WU570E:179 kg (393 lb) WU590E:73 kg (161lb)
Quick Check Drive Commercial	346 lbs (157 kg)

*Amperage shown is minimal circuit rating.

¹Isolated ground recommended.

OVERALL FOOTPRINT

*Recommended site layout for Quick Tread Heavy™ in-line with Quick Check Commercial.

- A:** 41in. / 1041 mm. QCHD Footprint Length.
- B:** 265 in. / 6731 mm. Typical Max Wheel-base.
- C:** 78 ft. / 23 m Total Typical Recommended Area Length (including short focal length camera).
- D:** 20 ft. / 6 m Recommended Bay Width.
- E:** 75 ft. / 23 m of communication cables connect console to Quick Tread Cabinet. Add cable as necessary.
- F:** 174 +/- 6 in. / 4420 +/- 152 mm. Tower Spacing, face-to-face.
- G:** Distance from external camera to QCD Tower is dependent on many variables. See 7296-TE for full details.
- H:** QTH Length 56.5 in / 1359 mm

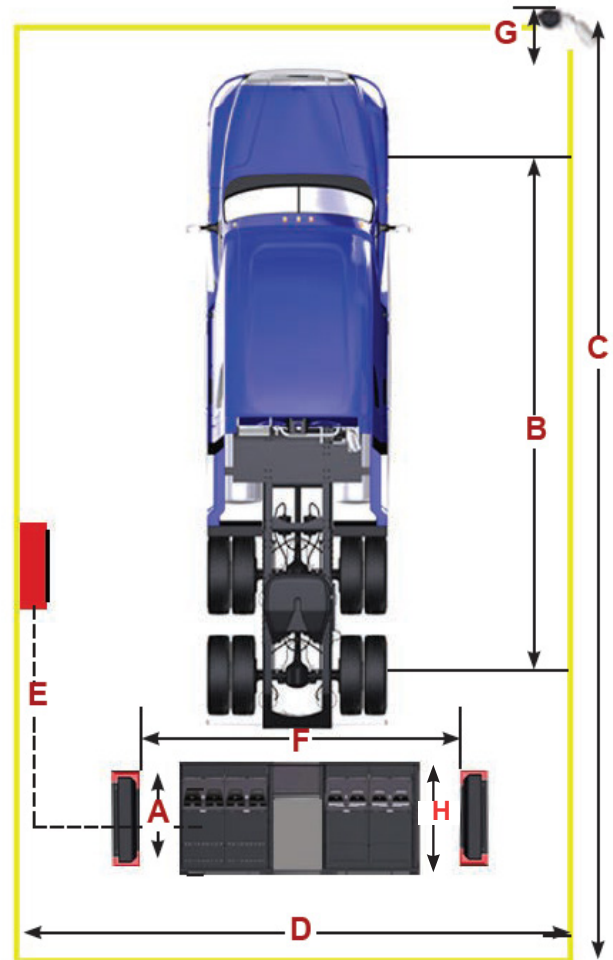

Continued on Page 2

For inspection information visit:
<https://www.hunter.com/en-int/>

For general inquiries visit:
<https://www.hunter.com/en-int/>
or call
1-314-731-3020

For local contact visit:
<https://www.hunter.com/en-int/contact/>

Form QS07966-05, 11-21
Copyright © 2021 Hunter Engineering Company

QUICK CHECK COMMERCIAL CABINET DIMENSIONS

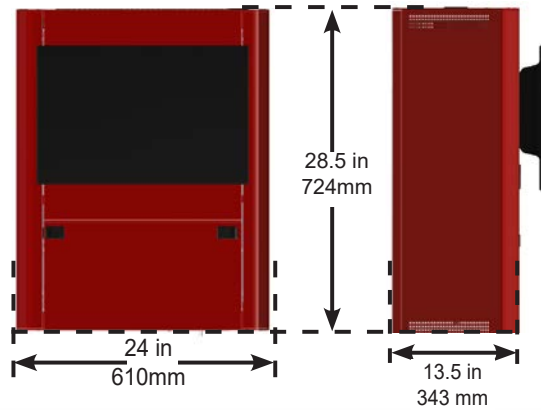

QUICK CHECK COMMERCIAL DIMENSIONS

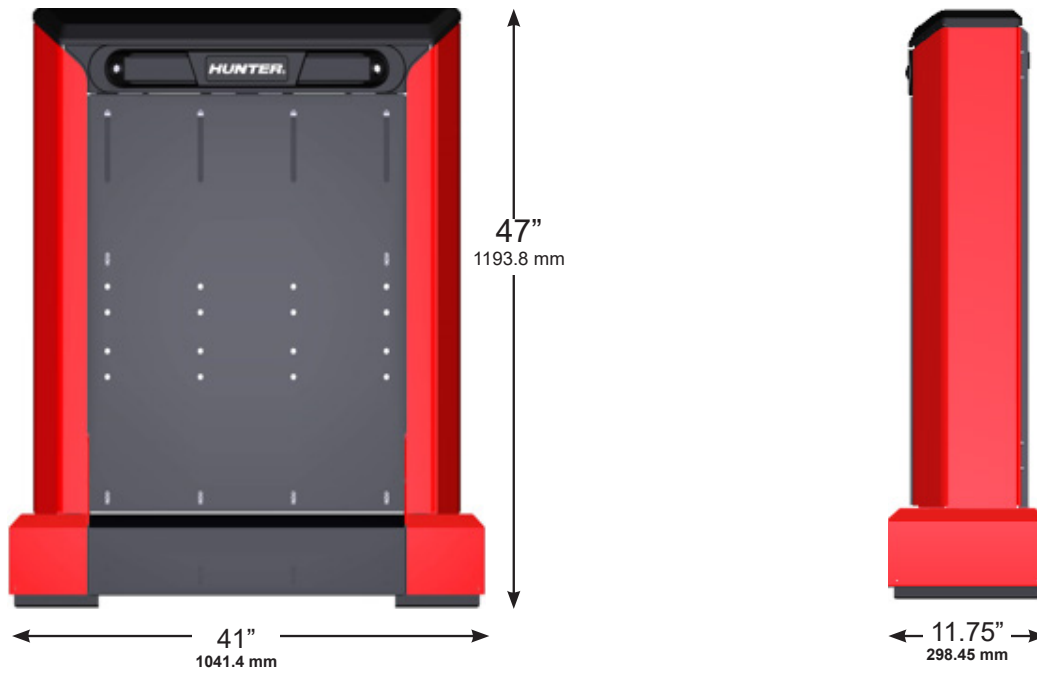

Example Configuration shown. Actual Pad Size Dependent on vehicle length.

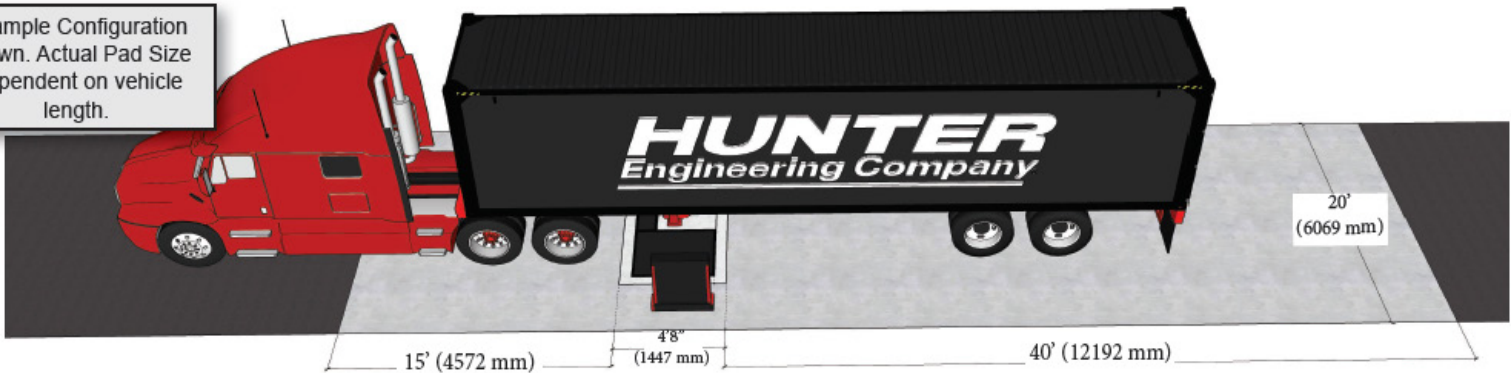

Quick Tread Edge™ DIMENSIONS

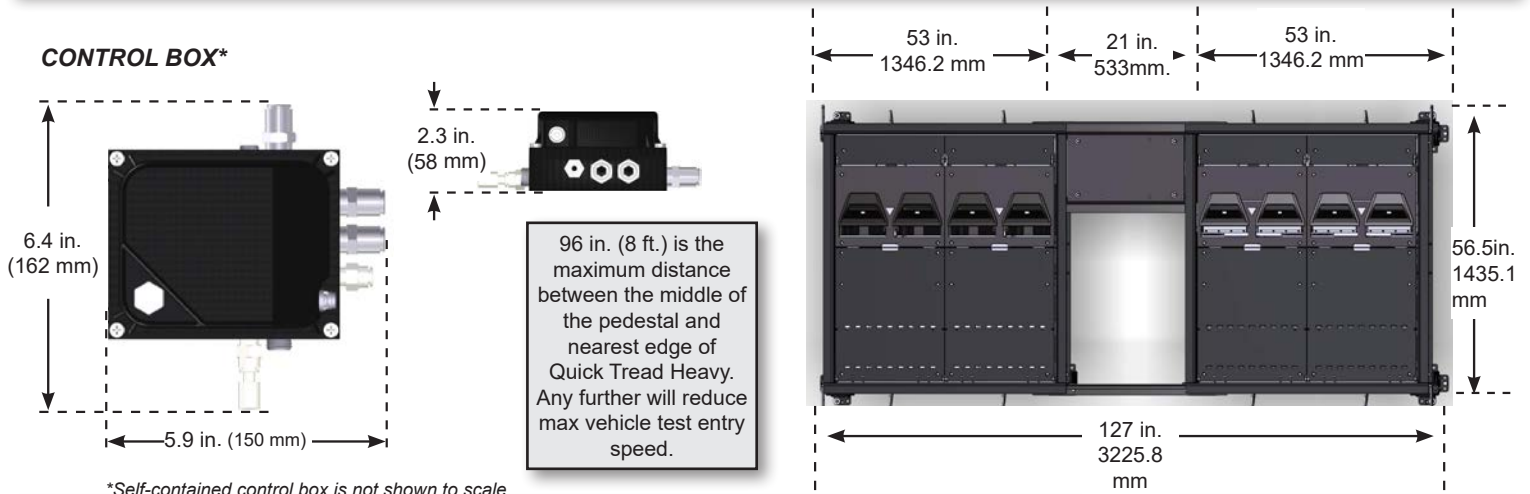

SUBSTRUCTURE SPECIFICATIONS

Recommend contacting local Hunter representative to verify installation prior to pouring concrete. Visit hunter.com/find-a-rep or call 800-448-6848.

SINGLE POUR TUB METHOD

