



PRODUCT NEWS

217

Equipment: Wheel balancers Truck

Subject: T 650 Truck new universal wheel balancer

Dear Sirs,

we are proud to announce that the new **T 650 Truck** universal wheel balancer for truck, bus, light commercial vehicle, and car wheels is now available for sale.

Available in motorised- or hand-spin versions.

Compact and lightweight. It is the most compact balancer in the whole range, featuring the most advanced programs available in top of the range models.

IDEAL FOR MOBILE ROAD SERVICE AS WELL AS SMALL SIZE WORKSHOPS AND GARAGES

Bright digital display with user-adjustable dual display for immediate and intuitive access to all programs and functions

New generation measuring unit. A 40 mm shaft ensures precision and reliability



Hand driven **in-built wheel lifter** for effortless work without using the foot pedals. Can lift wheels weighing up to 150 kg ensuring the best wheel centring at all times

Subject: T 650 Truck new universal wheel balancer

Main features:

- **Low balancing speed** (80 rpm truck / 100 rpm car) reduces spin times and lowers the risks connected with rotating elements, while also allowing for energy savings
- **Autosel 2D internal sensor** for automatic acquisition of distance and diameter 28" with automatic selection of balancing programs
- **AWC virtual wheel width sensor.**
- **DYN, STATIC, ALU and ALUP** balancing programs available (adhesive weights on the inside of the rim)
- Three systems for attaching the adhesive counterweights are available:
 - **manual at 12 o' clock** (conventional method)
 - **manual at 6 o' clock**
 - assisted by **laser pointer at 6 o'clock** (optional)
- **Electric brake** with the motorised version or **pneumatic brake** with the hand spin version
- Special programs available as standard:
 - **Hidden Weight** for hiding the weights behind the spokes
 - **Imbalance Optimisation (OPT)** to minimise static wheel imbalance
 - **Multioperator**
- **Energy saving mode**
- **Software update via USB**

Equipment



Dimension

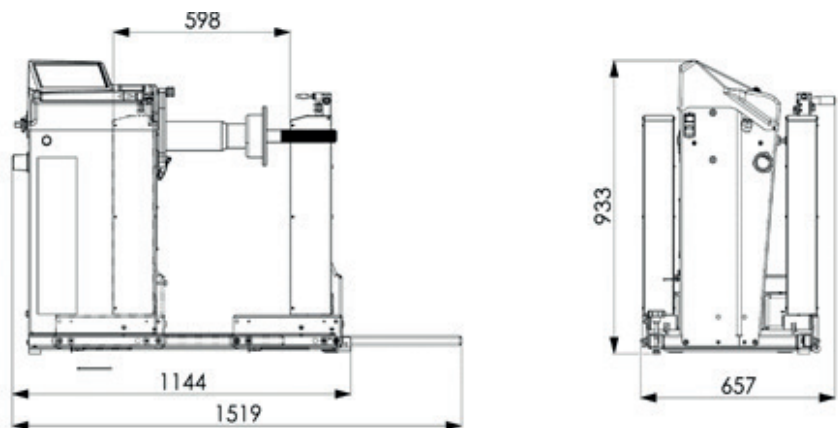

Full product details are provided below for correct product identification and accuracy of the order processing:





CODE	POWER SUPPLY	DESCRIPTION
0-21206500/25	200÷230V/1Ph/50-60Hz	T 650 MO WITH MOTORISED SPIN
0-21206501/25	200÷230V/1Ph/50-60Hz	T 650 HS WITH HAND SPIN

Subject: T 650 Truck new universal wheel balancer

RECOMMEDE ACCESSORIES

	<p>GTR40 EVO - Premium steel quick nut (suitable for T 650 MOT)</p>	<p>8-21100275</p>
	<p>GTV40 -Basic ring nut (suitable for T 650 MOT)</p>	<p>8-21900194</p>
	<p>GTM40 - Basic ring nut (only suitable for T 650 HS)</p>	<p>8-21100272</p>
	<p>ART40 EVO - Premium Heavy-Duty adaptor Kit for 10-8-6 holes</p>	<p>8-21100269</p>
	<p>KCT40 EVO - Heavy-Duty cones kit - \varnothing 159 ÷ 180 mm/ 198 ÷ 204 mm - \varnothing 220 ÷ 281 mm</p>	<p>8-21100268</p>
	<p>ARU40 EVO - Centering cones kit for car wheels \varnothing 42 ÷ 156 mm)</p>	<p>8-21900191</p>
	<p>L&L KIT - LASER & LED KIT</p>	<p>8-21100238</p>

Subject: T 650 Truck new universal wheel balancer

	<p>LASER BLADE KIT - New accessory available to integrate a laser blade in the Autosel of the measuring detectors</p>	<p>8-21120022</p>
	<p>TRUCK TROLLEY KIT for an easier handling of the wheel to calibrate</p>	<p>8-21101400</p>
	<p>ROLL-BAR KIT - Safety roll-bar</p>	<p>8-21101401</p>
	<p>ACCESSORY RACK - Accessory holder</p>	<p>8-21101402</p>